



MAXIEM 3060 JetMachining Center

The next generation MAXIEM® 3060 JetMachining® Center sets a new standard for abrasive waterjet machining. Faster, smoother, and more precise, the MAXIEM 3060 is ideal for a wide range of modern large format machining needs. The exclusive advanced Intelli-TRAX® digital linear encoder provides one-micron resolution instant feedback to the motor control system so the machine knows precisely where the cutting head is at all times. The mobile control station with widescreen display provides flexibility in controller positioning. Optional accessories such as the A-Jet® for 5-axis cutting and taper compensation and Collision Sensing Terrain Follower for accurate machining of warped materials expand your JetMachining capabilities and dramatically improve production.

FEATURES & BENEFITS

- Fast cutting speeds and high precision that is backed by our exclusive Intelli-MAX® Software with real world cutting data
- Programmable Motorized Z-Axis with a precision OMAX MAXJET®5i Nozzle boosts productivity and process efficiency
- Drive system protected against water, dirt, and grit
- Powerful all-in-one controller computer with large 23" screen
- Highly efficient, industry-proven direct drive pumps available up to 40 hp with operating efficiencies up to 85%
- Free Intelli-VISOR® SE System Monitoring simplifies routine maintenance planning to minimize downtime
- Optional Rapid Water Level Control for quiet submerged cutting
- Optional Bulk Abrasive Feed Assembly transports garnet from the assembly's large hopper into the Zero Downtime Hopper located at the Programmable Motorized Z-Axis
- Optional Variable Speed Solids Removal System (VS-SRS) designed for industrial use increases uptime through automated solids removal
- Factory tested as a complete system before shipping
- Machines a wide range of materials and thicknesses, from metals and composites to glass and plastics
- Designed and manufactured at the OMAX factory in Kent, Washington, USA
- Does not create heat-affected zones or mechanical stresses
- No tool changes & minimal fixturing dramatically reduce setup
- Convenient controller storage drawers keep essential tools and spares close by to maintain machine uptime
- Uses substantially less cooling water than inefficient hydraulic intensifier pumps
- Small, efficient footprint for minimal floor space utilization
- Lowest electrical consumption compared to other pump technology
- Leaves behind a satin-smooth edge, reducing secondary operations
- No noxious fumes, liquid or oils used in, or caused by, the machining process
- Environmentally "green" system uses only natural garnet abrasive and water in the cutting process

MACHINE DIMENSIONS

Footprint (without controller)	24'6" x 15'8" (7,468 mm x 4,775 mm)
Weight (tank empty)	8,700 lb (3,946 kg)
Height	9'6" (2,896 mm)
Operating Weight (with water in tank)	53,000 lb (24,040 kg)

WORK ENVELOPE

X-Y Cutting Travel*	20'6" x 10'2" (6,248 mm x 3,099 mm)
Z-Axis Travel*	12" (305 mm)
Table Size*	22'9" x 10'8" (6,934 mm x 3,251 mm)

DRIVE DESCRIPTION

- Brushless servo motors
- Stainless steel hardened precision ground shaft ways
- Real-time closed loop feedback with digital drives
- Bridge-style Y-Axis
- Intelli-TRAX drive technology with precision linear encoders
- Precision Programmable Motorized Z-Axis

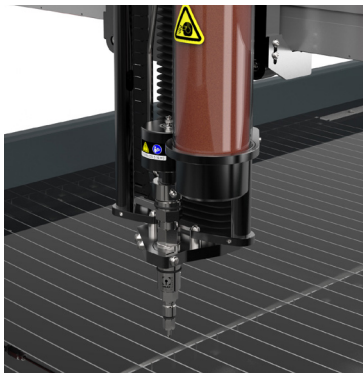
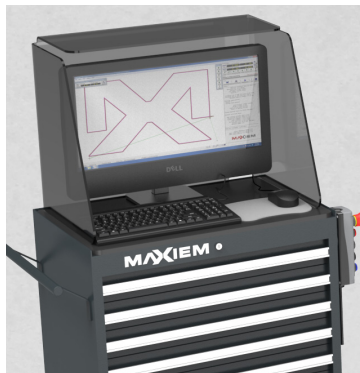
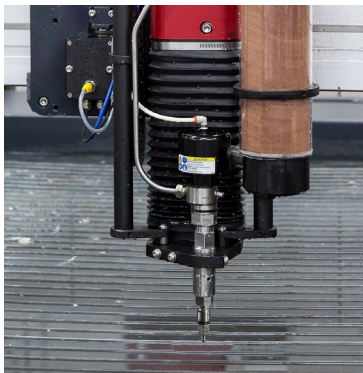

STANDARD MODEL SPECIFICATIONS

Material Support Slats	60 4" x 14Ga Galvanized Steel (102 mm x 2 mm)
Maximum Supported Material Load	300 lbs/sq ft (1,465 kg/sq meter)
Electrical Requirements	3-Phase, 380-480 VAC ±10%, 50-60 Hz
Speed	500 in/min (12,700 mm/min)
Linear Positional Accuracy*	±0.003" (±0.076 mm)
Repeatability*	±0.001" (±0.025 mm)

OPTIONAL ACCESSORIES

- A-Jet 5-Axis Cutting Head with Smart Taper Control
- Rapid Water Level Control for submerged cutting
- Intelli-VISOR EX Monitoring Expansion Package
- OMAX Mini MAXJET 5i Nozzle
- 7/15 Mini MAXJET5 Nozzle
- Bulk Abrasive Delivery Assembly
- Terrain Follower/A-Jet
- Collision Sensing Terrain Follower
- Manual Tilt Z-Axis
- Large Solids Removal System
- Material Holding Kit
- Waterjet Brick Kit
- Extended Slat Package
- Additional Seats of Intelli-MAX Software Suite
- Variable Speed Solids Removal System (VS-SRS)
- Water-only MAXJET 5 Nozzle
- Laser Feature Finder
- Z-Axis Pneumatic Drill
- Splash Shield Kit
- Water Resistant Keyboard and Mouse
- Access Control Circuit Interface for safety interlocks
- Catcher Tank Armor Plating
- Laminar Filter
- Air and Water Conditioning Kit
- Water Recycling System
- Bridge-mounted Pause Button and USB Port

*Optional accessories may reduce cutting travel. Photos may show optional accessories. For a complete list of accessories, contact an OMAX sales representative. Accuracy specifications are at 72° F (22° C) Pumps are built to meet UL and CE specifications. Contact OMAX for detailed utility requirements.

ABOUT OMAX

OMAX is the global total solutions provider in advanced abrasive waterjet systems. Our intuitive Intelli-MAX Software Suite simplifies programming and reduces setup times, increasing your productivity. OMAX engineers continue to innovate technology for abrasive waterjet machining, from proven 4th generation pump designs to cutting edge drive systems with micron-level accuracy. With the largest abrasive waterjet support network in the world, OMAX continues to shape the future of waterjets.

To see how a MAXIEM JetMachining Center can save you time and money, call or visit our website and request a free part analysis today.

ABRASIVE WATERJET
v.s. OTHER METHODS

WWW.OMAX.COM/COMPARE

CE Specifications subject to change without notice.
600129F © OMAX Corporation September 2016

WWW.OMAX.COM
Made in the USA

OMAX CORPORATION
21409 72nd Avenue South
Kent, WA 98032
TEL 1-253-872-2300 / 1-800-838-0343
FAX 1-253-872-6190

